

# Customer centric technical documentation

## Miel De Schepper

### Trisoft HQ - Mechelen

Mechelen Intercity Business Park  
Generaal De Wittelaan 17 Box 9  
B-2800 Mechelen  
Belgium  
Phone: +32 (0)15 400 970  
Fax: +32 (0)15 400 971  
[www.trisoftcms.com](http://www.trisoftcms.com)

### Trisoft San Jose

2570 North First Street Suite 360  
San Jose  
95131 California  
United States of America  
Phone: +1 (408) 838-410  
Fax: +1 (408) 743-3601  
[www.trisoftrcms.com](http://www.trisoftrcms.com)



**With SDL investment (49%) and SDL infrastructure behind it,  
Trisoft is now one of the largest Component-based content  
management systems for technical writing organizations.**

**Trisoft HQ - Mechelen**

Mechelen Intercity Business Park  
Generaal De Wittelaan 17 Box 9  
B-2800 Mechelen  
Belgium  
Phone: +32 (0)15 400 970  
Fax: +32 (0)15 400 971  
[www.trisoftcms.com](http://www.trisoftcms.com)

**Trisoft San Jose**

2570 North First Street Suite 360  
San Jose  
95131 California  
United States of America  
Phone: +1 (408) 838-410  
Fax: +1 (408) 743-3601  
[www.trisoftcms.com](http://www.trisoftcms.com)



- **Founded in 1987**
- **Independent software vendor**
  - SDL has taken a 49% investment in Trisoft
  - This makes Trisoft one of the largest XML/DITA Technical Publications Solutions in the market
- **Headquarters in Belgium**
  - US office (San José)
  - Worldwide infrastructure and support via SDL (35 offices in 50 countries)
- **Trisoft CMS: Component based CMS for Technical documentation**
- **Partners:**
  - Citec (Finland, Sweden, India, China),
  - ServiceXpert (Germany),
  - Tanner (Germany)
  - Seicodyne (Switzerland)
  - I Ctrl (Netherlands)
  - Just Systems (XMetaL), PTC (Arbortext), In.Vision Research (Xpress Author), Adobe (FrameMaker), Antenna House
  - Suite Solutions, Comtech, DC Labs
  - SDL, Idiom Technologies (Worldwide)
  - ...

# SDL – the company



- Publicly traded company with \$250 m annual revenues (2007)
- 50 offices across 30 countries
- Over 2,000 employees
- Over 150,000 licenses in the translation supply chain (90% market share)
- Over 250 enterprise deployments

# Technology Acquisitions



The logo for SDL TRADOS TECHNOLOGIES, with "SDL" in yellow and "TRADOS" in white on a dark green background, and "TECHNOLOGIES" in white below.	<p>June 2005 Acquired Trados, leader in translation memory and terminology software. Gained 90% market share</p>
The logo for SDL Passolo, with "SDL" in yellow and "Passolo" in green.	<p>June 2007 acquired leader in software for localizing software</p>
The logo for SDL tridion, with "SDL" in green and "tridion" in a lowercase green font, separated by a yellow and green circular graphic.	<p>2007 acquired one of the leading Web Content management solutions</p>
The TRISOFT logo, featuring a stylized globe icon and the word "TRISOFT" in a bold, green, sans-serif font.	<p>12/ 2007 Took 49% percent investment in this leading Technical Publications CMS</p>
The logo for id10m, with the word "id10m" in a black, lowercase, serif font, and a small registered trademark symbol.	<p>1/ 2008 Acquired one of the leading providers of globalization management systems</p>

# One stop shopping



CREATE

MANAGE

TRANSLATE

PUBLISH

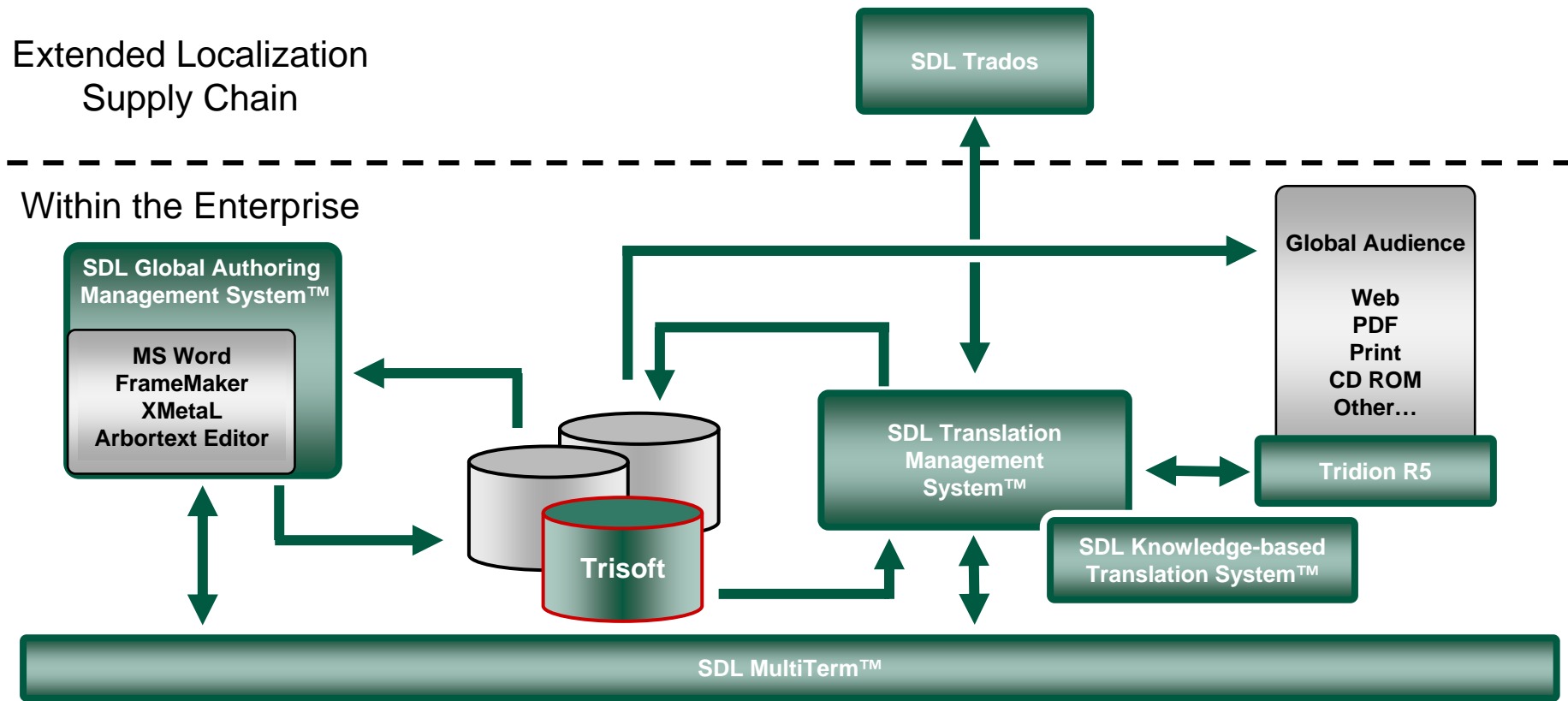

# Selection of Trisoft CMS client references



- **What is customer centric technical documentation?**
- **Pain area's and market drivers**
- **The solution**
- **Q&A**

# What is customer centric technical documentation?



- **In the language of the customer**
- **For the specific product of the customer**
  - The selected options / product configuration
  - The S/N or product revision
  - Distribution channel
- **Units of measurement**
- **Adapted to the readers level of experience**
- **Quality and consistency**
  - Terminology
  - Consistency between different in box publications

- **What is customer centric technical documentation?**

- **Pain area's and market drivers**

- **The solution**

- **Q&A**

# Specific pain areas



**1** Prod. Life cycle & time to market

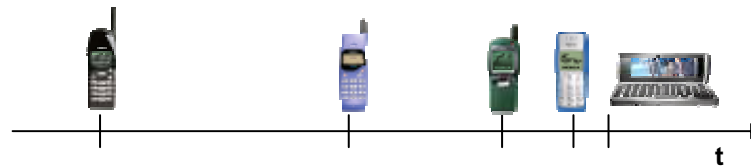

**2** Customized communication



- Air cooled
- Water cooled



- Miles, Pound, °F,...
- Km, Kg, °C...

**3** Multiple live editions



**4** Multiple translations



**5** Multiple output media

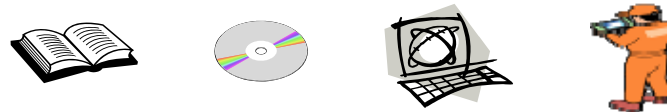

**6** Complex TC management

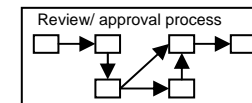
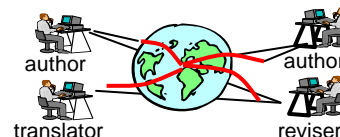

“Mass customization”

Combined with a constant pressure to cut costs  
 • “Do more with less money”

- **Product life cycle becoming shorter and shorter**
  - Less than 1 year for high tech
- **Product introduction at all global markets at the same time becomes very important**
- **Delay in product introduction → risk for the revenues of your company**
  - E.g. Product with one year product life
  - One month delay brings 8% of your revenue in danger!
- **Translation comes at the very end of the process**

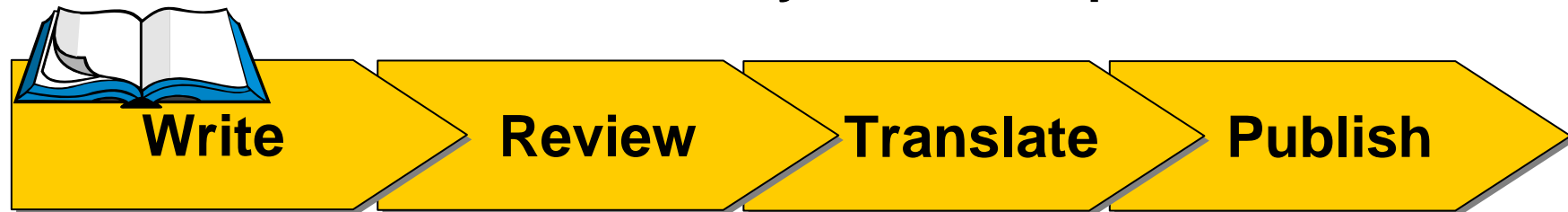

- **Peak loads at LSP**

# Cost estimates (price/page)

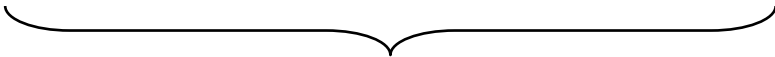
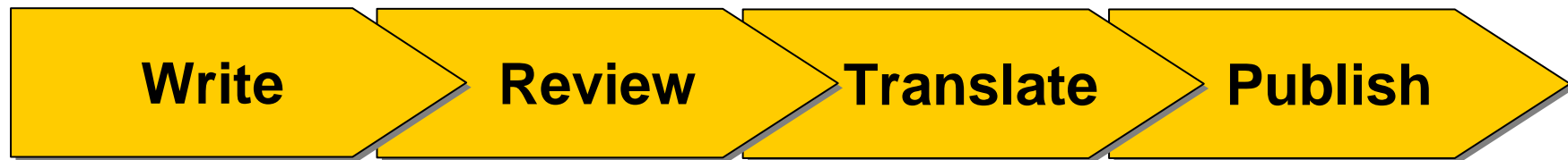

**200 €**

**600 €**

**160 €**

**For 20 languages**

## ● Important for repeat sales

## ● Consistency

- between all topics in a publication
- Between all different in box publications
  - *User manual*
  - *Quick reference card*
  - *Warranty...*

## ● Uniform Terminology

- **What is customer centric technical documentation?**

- **Pain area's and market drivers**

- **The solution**

- **Q&A**

# Write once : Re-usable components



...

# Re-use many

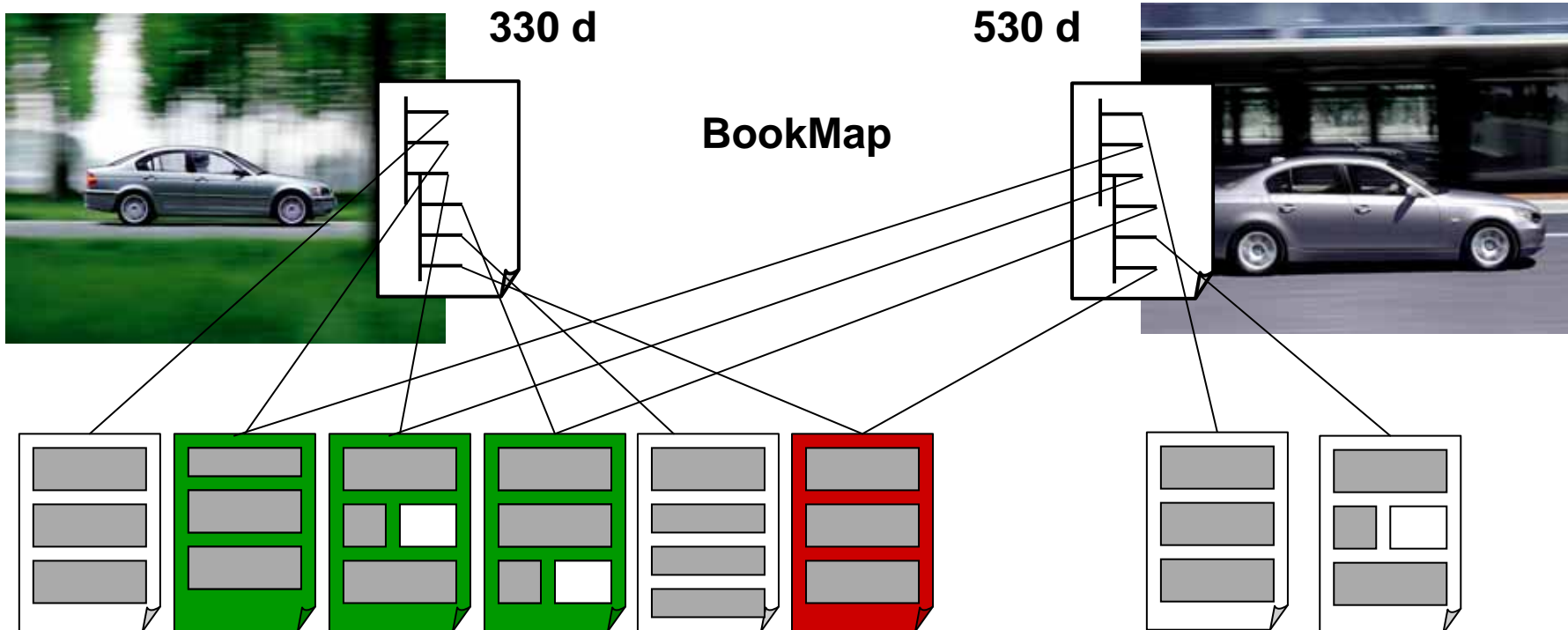

Single Source Topics



# Translate once, re-use many



- Modules only need to be translated once

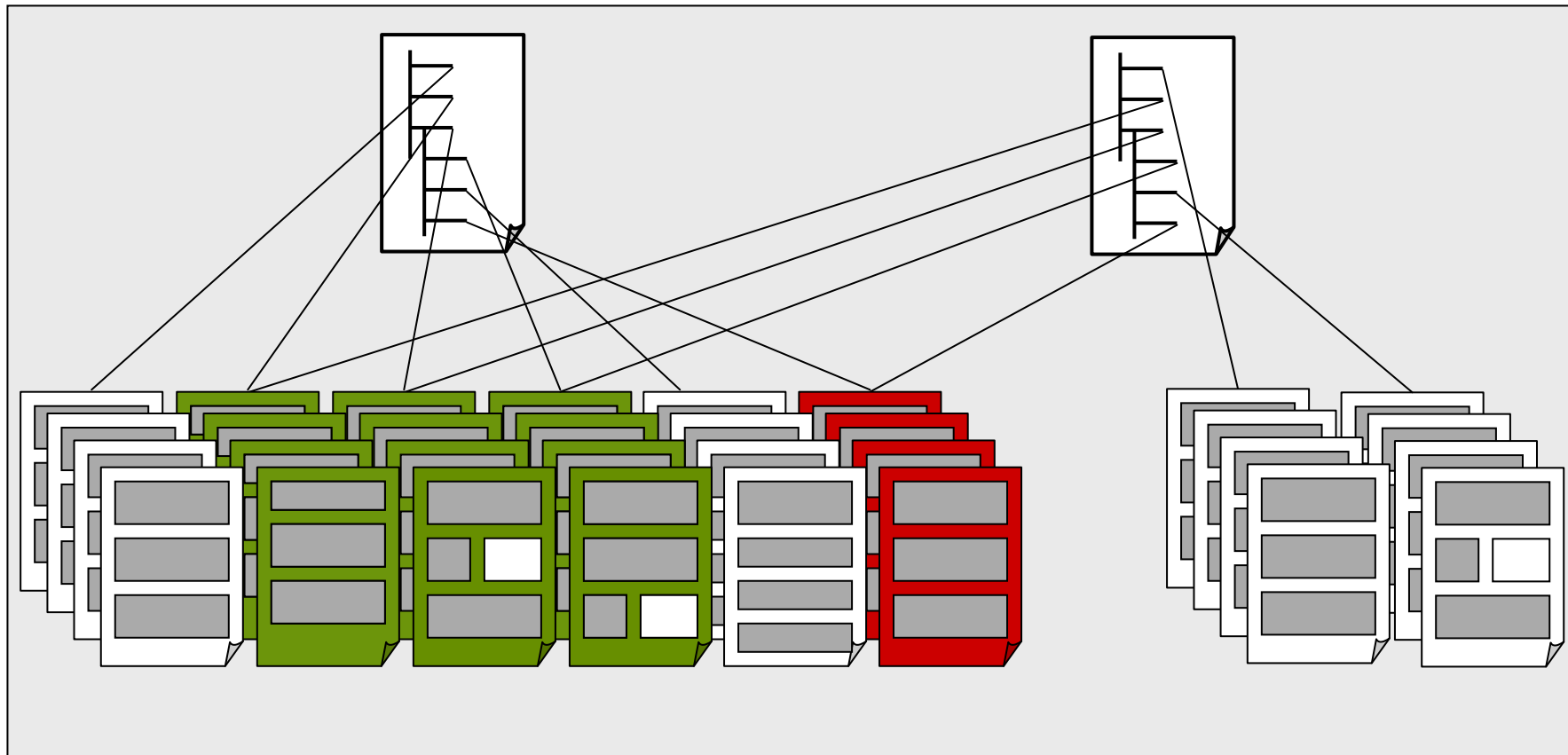

- Cost reduction

# Integrated Translation involves



- **Unicode**
- **Managing language-version combinations of topics**
- **Inheriting target languages from publication to topics**
- **Generating translation requests**
- **Support for Pivot languages**
- **In context Pre-translation**
- **Initiation of translation by translation coordinator**
- **Integration of CMS with TMS and TM**
- **Publishing of multi-lingual documents**
- **Index sorting**
  
- **Reference: Nokia uses 80+ languages**

# Translate as soon as topic is ready



- Reduce time to market

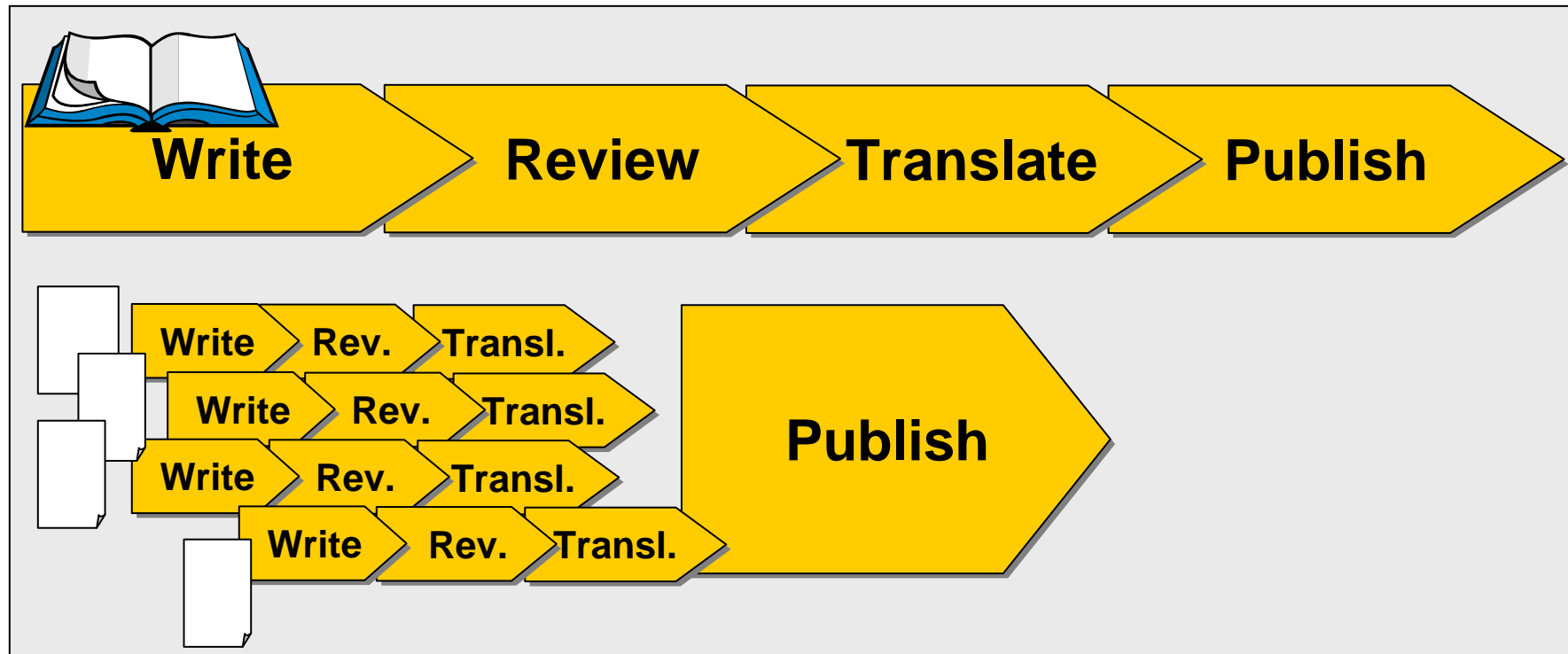

# Publish in batch



- Write in DITA/XML
- Publish in batch (without human intervention)
- Cost reduction

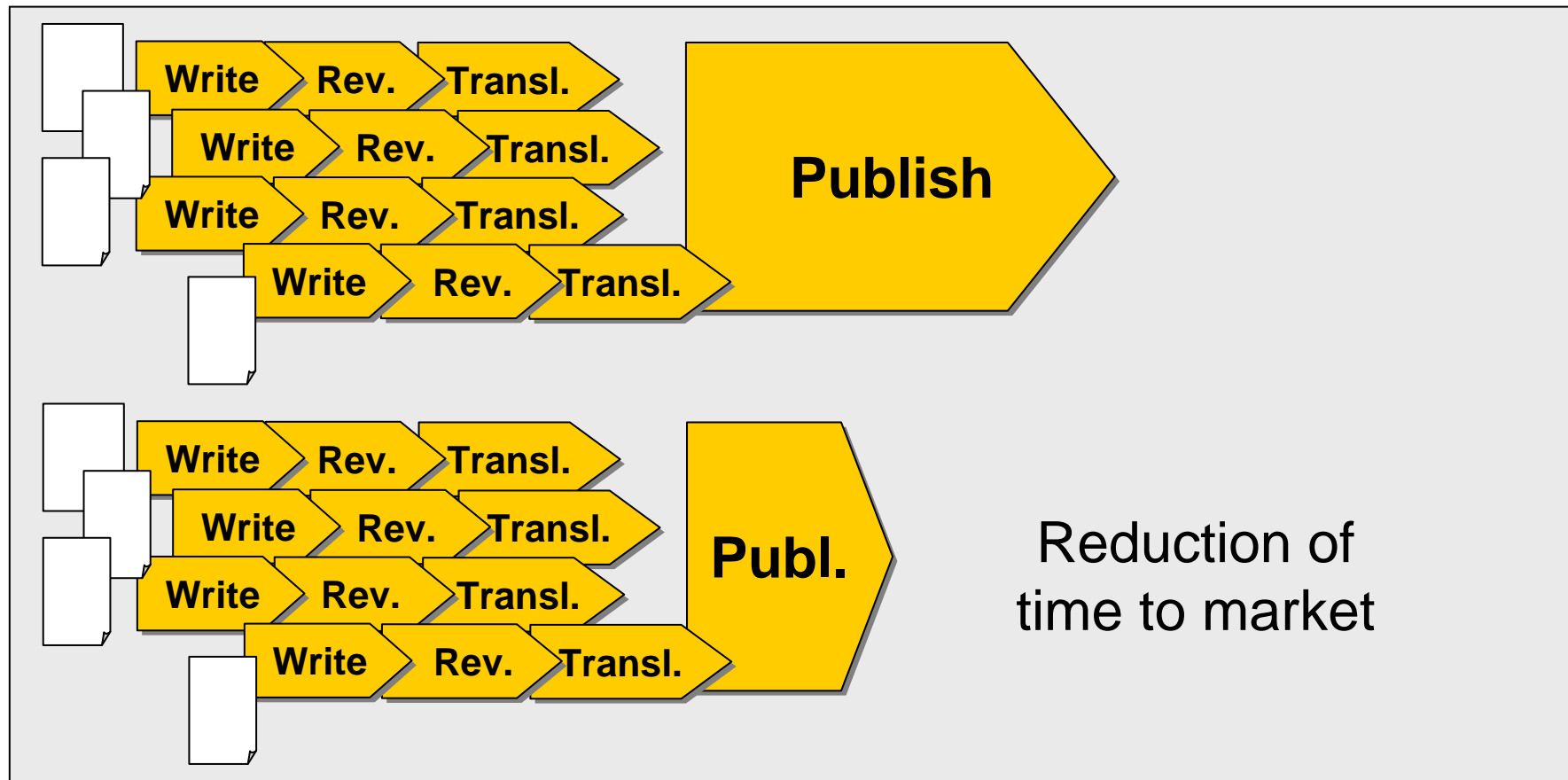

# Customer centric: siblings



**Water cooled**

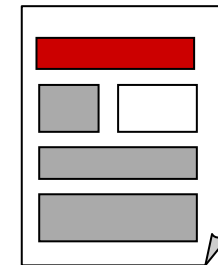

**Air cooled**

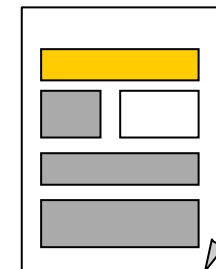

# Customer centric: Universal topics and conditional publishing

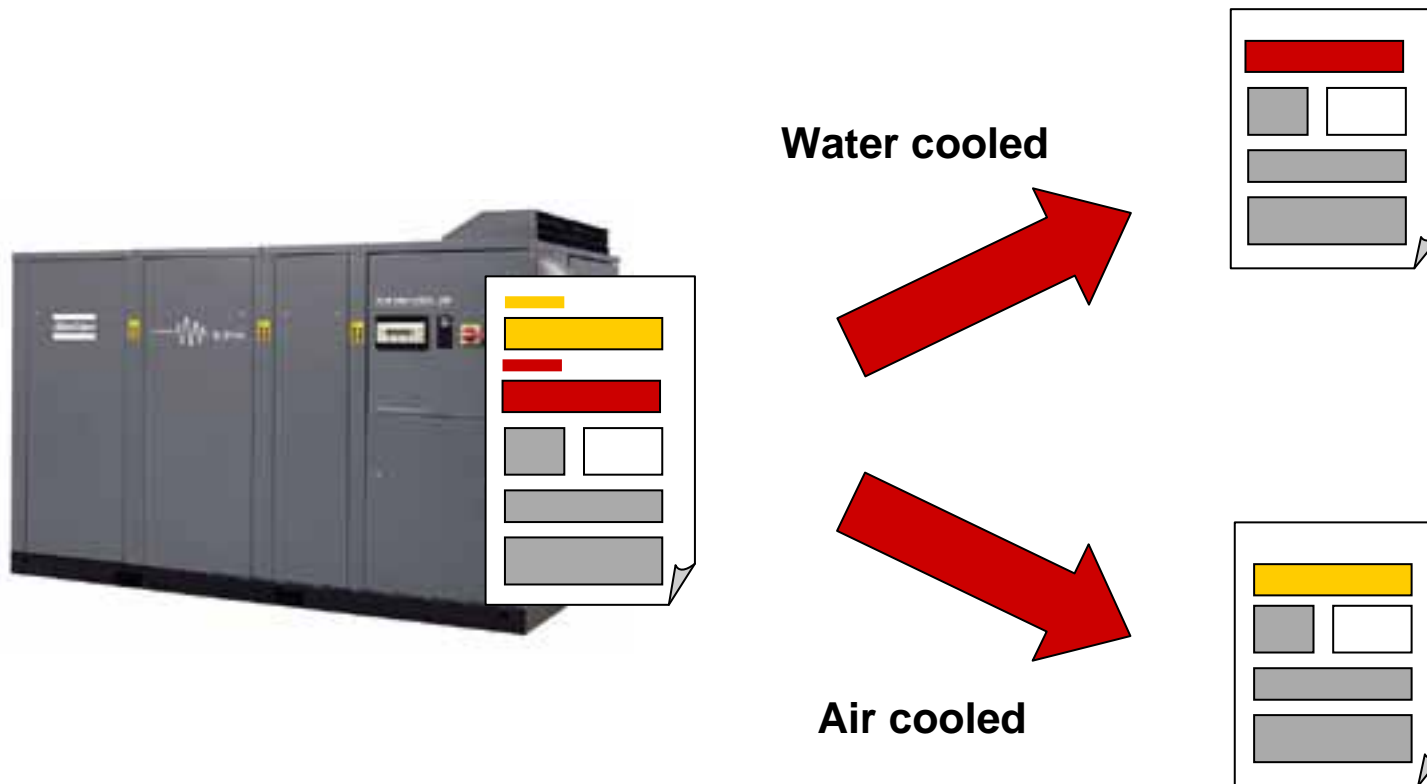

# Conditional publishing involves



- **Condition manager**
- **Condition builder integrated in authoring tool**
- **Validation at check in**
- **Publishing Context**
- **Conditional filtering**

# The publication object



● **Publication Object**  
=> output

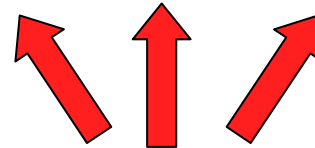

Electronic output format

Layout template

Baseline

**Context**

Variable definition

● **Master Document**  
(e.g. DITA Maps)  
=> assemblage/ structure

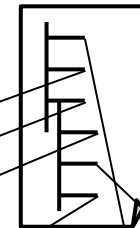
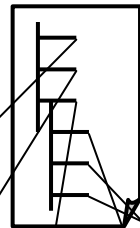

● **Components**  
(e.g. Topics, illustrations...)  
=> content

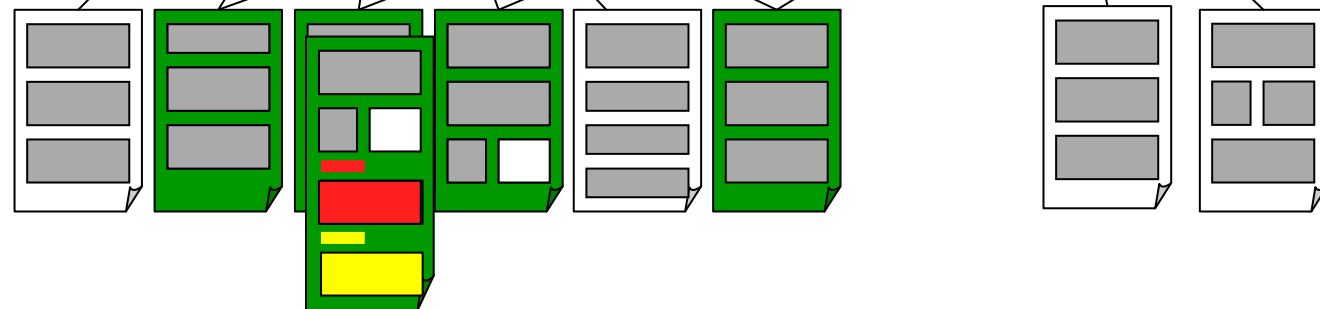

## ● Terminology

- SDL Global Authoring Management System

## ● Consistency

- Between the different topics in a publication
- Between the different in box publications
  
- Solution: Baseline object

# Baselines

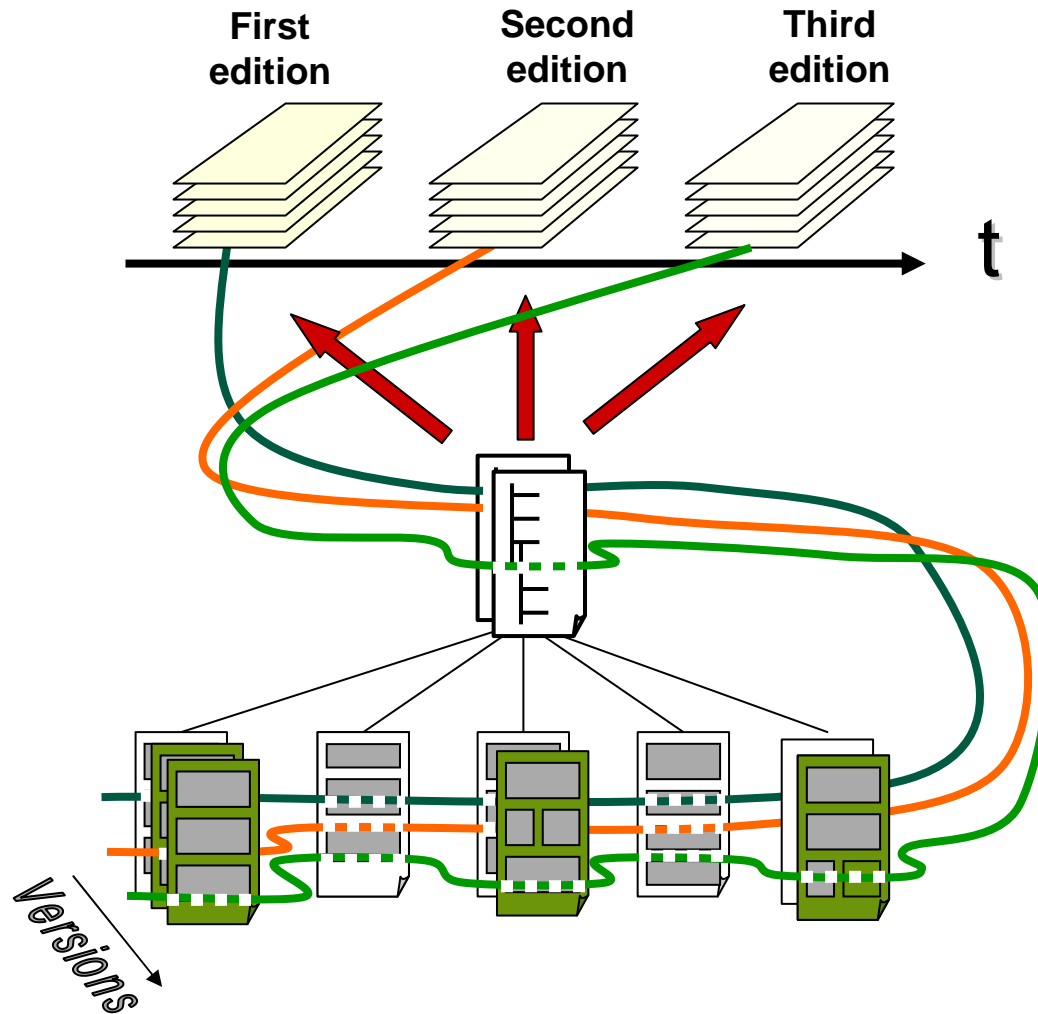

Which version of a topic goes in a specific edition of a publication

# One stop shopping



CREATE

MANAGE

TRANSLATE

PUBLISH

Extended Localization  
Supply Chain

Within the Enterprise

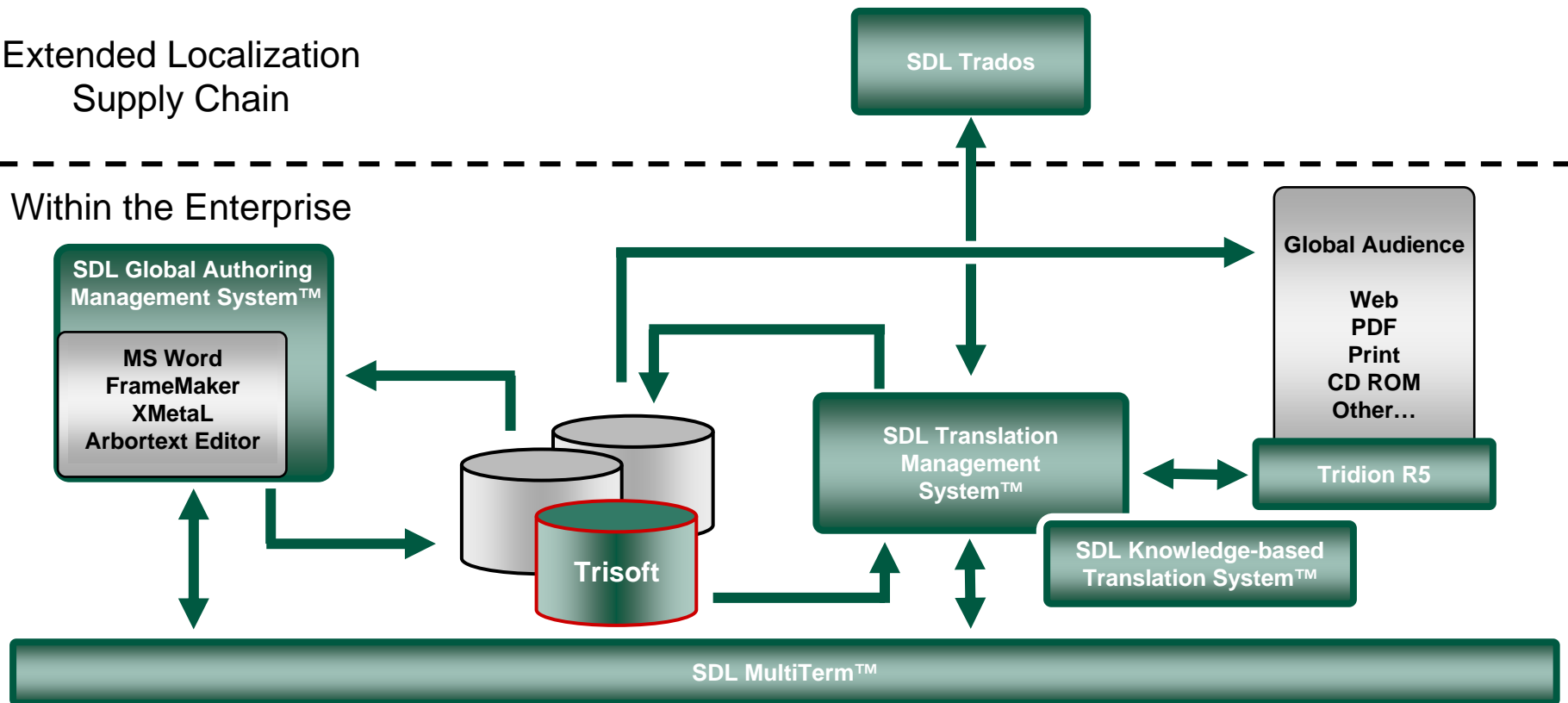

# Agenda



- **What is customer centric technical documentation?**

- **Pain area's and market drivers**

- **The solution**

- **Q&A**